IoT BASED FIRE FIGHTING AND LIVE TRACKING ROBOT

Geeta Aghav^{*1}, Sanket Bangar², Shraddha Pawale³, Dr. S. M. Walke⁴

^{1,2,3}Student & ⁴Professor, Electronics and Telecommunication Department, Ahmednagar Jilha Maratha Vidya Prasarak Samaj's Shri. Chhatrapati Shivaji Maharaj College of Engineering, Nepti, Ahilyanagar, Maharashtra, India.

Article Received: 4 May 2026, Article Revised: 24 May 2026, Published on: 14 June 2026

***Corresponding Author: Geeta Aghav**

Student Electronics and Telecommunication Department, Ahmednagar Jilha Maratha Vidya Prasarak Samaj's Shri. Chhatrapati Shivaji Maharaj College of Engineering, Nepti, Ahilyanagar, Maharashtra, India.

Doi: <https://doi-doi.org/101555/ijarp.8356>

I. ABSTRACT

The Internet of Things (IoT) has opened new possibilities for developing intelligent systems that can respond to critical emergencies such as fire accidents. This paper presents the design and implementation of an IoT-Based Fire Fighting and Live Tracking Robot capable of detecting fire, extinguishing it, and sharing real-time location and status updates. The proposed system integrates flame sensors, temperature sensors, and a camera module for live monitoring. The robot is controlled remotely through IoT platforms, allowing users to observe and manage operations via the internet. A Wi-Fi-enabled microcontroller, such as Node MCU or Arduino with ESP8266, serves as the main control unit, ensuring seamless data transmission between sensors and the cloud. The system enhances safety in hazardous environments by reducing human intervention and providing immediate fire detection, suppression, and area surveillance. Experimental results demonstrate the robot's efficiency in detecting flames, navigating towards the source, and extinguishing small-scale fires effectively. This approach offers a cost-effective and reliable solution for industrial, residential, and institutional fire safety applications.

II. INTRODUCTION

Fire is one of the most destructive hazards that can cause severe damage to life, property, and the environment. In many cases, delays in detection and response lead to the rapid spread of fire, making traditional firefighting methods risky and inefficient. Firefighters are often required to enter dangerous areas filled with smoke, heat, and toxic gases, putting their lives

in danger. Hence, there is a growing need for an automated system that can detect and extinguish fire without direct human intervention.

The advancement of **Internet of Things (IoT)** technology has enabled the development of smart systems capable of real-time monitoring, communication, and control. IoT-based robotic systems can collect environmental data through sensors, process it using microcontrollers, and share information over the internet for analysis and decision-making. Leveraging these capabilities, an IoT-based fire-fighting robot can detect fire sources, send instant alerts, and take appropriate actions to suppress the fire autonomously.

The proposed **IoT-Based Fire Fighting and Live Tracking Robot** is designed to detect fire using flame and temperature sensors, navigate towards the fire location, and extinguish it using an automated water or extinguisher system. The robot's movement and surrounding environment can be monitored remotely through a live video stream. A Wi-Fi-enabled microcontroller such as **NodeMCU** or **ESP8266** serves as the main control unit, allowing the robot to communicate with cloud-based platforms for data exchange and live updates.

This system not only enhances the efficiency of fire detection and suppression but also provides **live location tracking**, which helps operators monitor the robot's position in real-time. The robot can be deployed in industrial zones, warehouses, residential buildings, or any high-risk environment where human access is dangerous.

III. LITERATURE SURVEY

[1] Vyshnavi M. B. and Shikha Suresh S

This paper presents an IoT-enabled firefighting robot that can operate both autonomously and remotely. The robot connects to a Remote Desktop application via the Internet, allowing authorized personnel to monitor and control its functions. The system identifies different types of fires and selects the appropriate extinguishing method accordingly. This approach enhances human safety by reducing direct involvement in hazardous situations.

[2] Kshitiz Agarwal, Aishwarya Soni, Shilpi Mishra, and Geetanjali Jangid

In this study, the authors developed an autonomous firefighting robot designed to respond quickly to unexpected fire incidents. The robot is equipped with three flame sensors for fire detection and three infrared sensors for obstacle avoidance. Controlled by an Arduino microcontroller, it moves freely in the environment and automatically alerts the operator upon detecting a fire. The built-in water tank and pump system are then activated to extinguish the flames effectively.

[3] A.R.M.Raafeek,N.Satheeskanth,J.JoyMathavan,andA.Kunaraj

This paper proposes an IoT-based firefighting vehicle prototype that integrates multiple sensors and a GSM module for real-time fire alerts. When the system detects a fire, it notifies the user through GSM communication while simultaneously activating its servo motors to control the direction and water flow. This ensures accurate targeting of the fire source and efficient extinguishing performance.

[4] KristiKosasih,ErwaniMerrySartika,M.JimmyHasugian,andMuliadyMuliady

The authors discuss advancements in robotics technology that have led to the creation of specialized firefighting robots. Their design incorporates multiple sensors such as ultrasonic, compass, flame, thermal array, white light, and micro switch sensors. A microcontroller-based control system processes these sensor inputs to guide the robot's movement, detect fire sources, and extinguish flames autonomously. This multi-sensor approach enhances precision and adaptability in complex environments.

[5] S.Kavitha,KrishnarajendraSagar,MohamedTousif,NishanthC.R.,andLikithV.

This study introduces a compact firefighting robot powered by an ARM7 microcontroller that supports both manual and automatic operating modes. The system focuses on high-risk areas and is equipped with Wi-Fi connectivity, multiple sensors, and an integrated extinguisher. Its design enables quick fire detection and suppression while minimizing human exposure to danger. The robot's wireless operation also improves communication and remote accessibility during emergency scenarios.

IV. CIRCUIT DIAGRAM

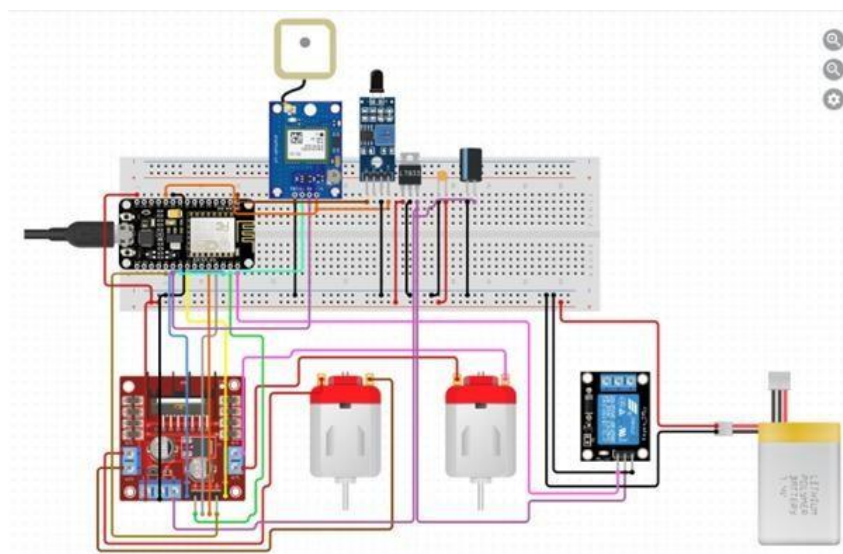

V. SYSTEM COMPONENTS

1. Microcontroller(ESP32/Arduino)

The ESP32 microcontroller serves as the central processing unit of the system. It is responsible for acquiring data from various sensors, processing the inputs, and executing appropriate control actions such as activating the water pump or motor driver. The ESP32 was selected because it has built-in Wi-Fi and Bluetooth, which enable seamless IoT connectivity with the Blynk cloud platform for real-time monitoring and control.

2. FlameSensor

The flame sensor detects the infrared radiation emitted by fire. When a flame is detected, the sensor sends a signal to the microcontroller to initiate the fire-extinguishing process. Multiple flame sensors can be placed in different directions to increase detection accuracy and range. The module's sensitivity can be adjusted using a potentiometer, ensuring reliable detection even under varying lighting conditions.

3. GPSModule(NEO-7M)

The NEO-7M GPS module is integrated into the robot to provide real-time location tracking. It outputs latitude and longitude coordinates, which are transmitted to the Blynk IoT application for live mapping. This feature enables users to monitor the robot's movement and current location remotely, which is particularly useful for outdoor firefighting operations or for locating the robot after deployment.

4. MotorDriver(L298N)

The L298N motor driver module is used to control the direction and speed of the two DC motors that drive the robot's wheels. It acts as an interface between the low-power control signals from the microcontroller and the higher current required by the motors.

5. DCMotors

The robot uses 12V DC gear motors to provide locomotion. These motors offer a balance between torque and speed, allowing the robot to move smoothly on flat or moderately rough surfaces. Differential drive control is implemented, enabling the robot to navigate accurately toward the fire source detected by the sensors.

6. WaterPump(SubmersibleType)

A 12V submersible water pump is employed to extinguish the fire by spraying water through a connect

ednozzle. Upon receiving the activation signal from the microcontroller (through a relay), the pump draws water from an onboard reservoir and directs it toward the detected flame.

7. RelayModule

The relay module functions as an electronic switch to control high-current components such as the water pump and motors. When triggered by the microcontroller, the relay allows the pump to operate safely without overloading the control circuit.

8. BatteryPackandPowerSupply

The robot is powered by a 3-cell (3S) 18650 Li-ion battery pack, providing a total voltage of 11.1V with each cell rated at 2200mAh. A 3S 10A Battery Management System (BMS) is integrated for protection against overcharging, over-discharging, and short circuits. The battery can be recharged via a female DC jack using a 12V 1A adapter. This configuration provides sufficient runtime for field testing and real-time operation.

9. IoTPlatform(BlynkApplication)

The Blynk IoT platform serves as the user interface for remote operation and monitoring. It displays live sensor readings, GPS coordinates, and robot status on a mobile dashboard. Users can manually control the robot's movement, activate or deactivate the water pump, and monitor fire detection alerts in real time. This integration of IoT connectivity enhances the system's accessibility and responsiveness.

10. Chassis and Mechanical Structure

The mechanical structure consists of a metal or acrylic chassis fitted with two DC motors, wheels, and a caster wheel for balance. The chassis provides mounting space for the pump, sensors, battery pack, and electronic modules. Its lightweight yet sturdy design ensures stability during operation and easy mobility in emergency scenarios.

VI. CONCLUSION

The proposed IoT-Based Fire Fighting and Live Tracking Robot successfully demonstrates how technology can enhance fire detection and suppression while reducing human risk. By integrating flame sensors, GPS tracking, and IoT connectivity through the Blynk platform, the robot can detect fire, alert users in real time, and extinguish flames either autonomously or via remote control. The system's wireless operation and live tracking f

eaturesmake it suitable for deployment in hazardous or inaccessible areas. This project highlights the potential of combining IoT, automation, and robotics to create a safer, faster, and more efficient fire response system.

VII. REFERENCE

1. N. Agarwal and Y.Rohilla,“FlameSensor-Based Autonomous Fire fighting Robot,” Conference Paper, First Online: September 10, 2021.
2. M. Sawant, R. Pagar, D. Zutshi, and S. Sadhukhan, “Fire Detection and Controlling Robot Using IoT,” Conference Paper, First Online: July 26, 2020.
3. S. Alone, K. Mahakalkar, T. Madankar, and P. Maske, “IoT-Based Fire Fighting Robot,” International Journal of Research in Engineering, Science and Management, vol. 3, no. 4, pp. 1–4, April 2020.
4. M. A. Althaf, K. Sushma, and P. Shivakumar, “IoT-Based Firefighting Robot Using Arduino,” International Journal of Engineering Technology and Management Sciences (IJETMS), vol. 6, no. 3, May 2022.
5. Ms.SowjanyaLagudu,Mrs.G.Mani;FireprotectionrobotusingIoT;AnInternationalOpenAccess, Peerreviewed,Referredjournalissued10thOctober 2023
6. Prof. Dr. S.N. Kini¹, Rutuja Wadekar² , Shweta Khatade³ , Sayali Dugane⁴ , Rutuja Jadkar⁵, Fire Fighting Robot Controlled Using Android Application, International Journal of Innovative Research in Science, Engineering andTechnology, ISSN(Online): 2319-8753. [7] Kristi Kosasih, E. Merry Sartika, M. Jimmy Hasugian, danMuliady, The
7. Intelligent Fire Fighting Tank Robot, Electrical Engineering Journal, Vol.1, No.1, October2010.